

napa:tech;

RECONFIGURABLE COMPUTING



PRODUCT BRIEF

Link-Programmable™ for Napatech FPGA-based SmartNICs

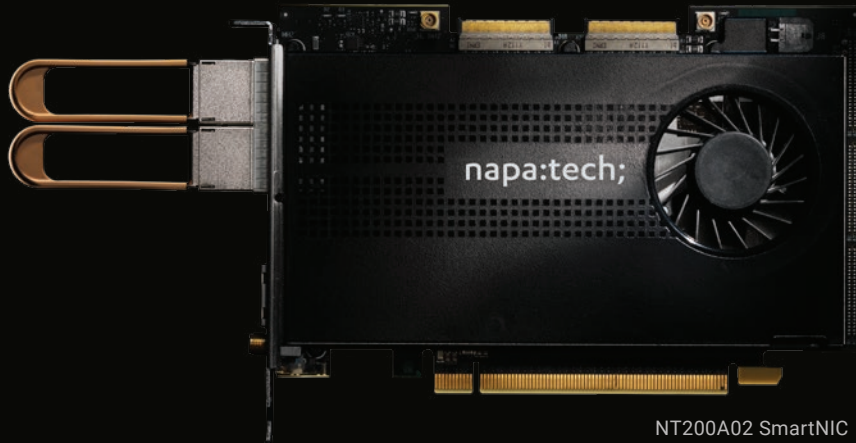

NT200A02 SmartNIC

Industry-Proven High-Performance FPGA Card

With Link-Programmable™, end users and OEMs can deploy their own FPGA IP on Napatech's industry-proven, ultra-reliable SmartNIC platform. Napatech FPGA SmartNICs are designed to meet the high standards of modern servers.

With computationally intensive algorithms evolving fast than silicon design cycles, Napatech's FPGA platform enables fast and worry-free deployment of core IP in-field, supporting new and increased workloads.

Superior Deployment Platform

Napatech SmartNICs remove the pain of certification and regulatory compliancy as all SmartNICs are fully qualified for operation worldwide. A Napatech SmartNIC as deployment target for your FPGA IP leaves only the choice of any standard COTS PCIe compliance server.

Super Computing at a Fraction of the Cost

All Napatech designs have high-speed interconnect ports which, combined with a superior thermal design, enable 8+ SmartNICs to sit adjacent in a single COTS server. This provides massive parallel processing capacity at a fraction of the cost of traditional clustered High Performance Computing (HPC). FPGAs as lookaside or inline processing can enable 40x performance over GPUs at a much lower power consumption.

Napatech offers SmartNIC hardware built on Xilinx and Intel FPGAs, with all hardware fully qualified and certified for production deployments worldwide.



Industry-Leading Reliability

When selecting a hardware solution, reliability is of the utmost importance. Software can be patched if faulty, but hardware needs a physical replacement, which is costly and complex. For all Napatech designs, performance and reliability are unconditional tenets. With ~300,000 hours of mean time between failures (MTBF), our hardware ensures uninterrupted, error-free operation for many years ahead – as validated by our long-term loyal customer base.

Superior Thermal Design

Efficient cooling allows you to fit more compute power into your rack space, which brings substantial TCO benefits. Designed for optimal thermal dissipation, Napatech SmartNICs offer both active and passive cooling options.

The active solution provides 100% self-contained cooling with no requirements for a specific server airflow. It exhales the dissipated energy outside the server through front plate cutouts, which gives customers the freedom to choose server designs without worrying about cooling capacity. To meet telco requirements, the passively cooled solutions are NEBS-compliant. A full body heatsink has been specially developed securing optimal cooling performance in the challenging NEBS applications for all critical components in the SmartNIC.

Ruggedized Design

Hardware resilience is essential for standard COTS server deployments. Modern servers have quick release PCI fastening mechanisms that allow for easy card replacement. However, some of these designs expose the card to vibration during transportation. Napatech SmartNICs are designed specifically to ensure resilience in harsh environments – and are deployed across a variety of industries, from data centers to the aviation industry, from military to sea applications.

Highest Standards of Excellence

Napatech has obtained certification for all products, ensuring global regulatory compliance and removing complexity and uncertainty from the integration process. As a certified PCI-SIG member, Napatech offers assurance and peace of mind that all hardware fundamentals are fully compliant and compatible across servers.

FPGA Development

For rapid prototyping and product maturing, Napatech Link-Programmable™ SmartNICs are fully supported by the Xilinx® Vivado® and Intel® Quartus® toolchains.

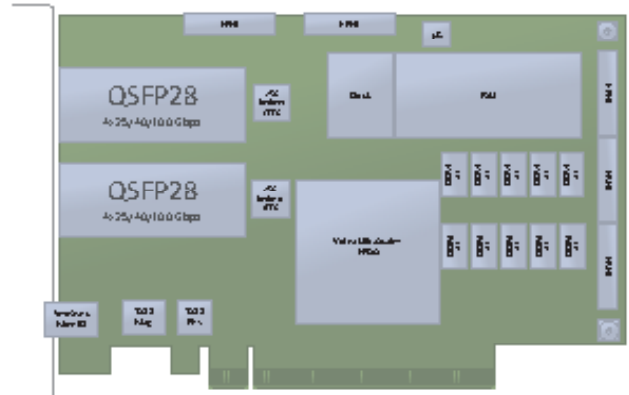

2-port 100G PCIe SmartNIC NT200A02

Applications Ideal for FPGA Processing

- Audio/video: DSP, speech recognition, HD video, computer vision
- Broadcast: RealTime video, encoders, EdgeQAM, switching/routing
- Datacenter: Switching/routing/load balancing, virtualization
- HPC: Data mining, AI inference, big data analysis
- Integrated circuit design: ASIC prototyping, HW emulation
- Financial: Crypto mining, high-frequency trading
- Medical: CT scan, MRI, X-Ray, PET, ultrasound
- Security: Image processing, industrial imaging, crypto, authentication

General Design Features

- Built for endurance and high MTBF
- Modular platform enabling options such as
 - Choice of RAM type, frequency, density, configuration
 - Choice of FPGA type, frequency, configuration
- High-speed interconnect ports allowing for Gbps bi-directional data transfer between cards without affecting PCIe or network ports
 - Ideal for NUMA-aware applications
 - Ideal for HPC cluster approach
- High-accurate time synchronization ports
- Exceptional thermal properties
 - Enable many cards in standard COTS servers
 - Reduce airflow design concerns
- Outstanding mechanical properties
 - Ruggedized design exposed to high G forces for qualification
 - Shock JESD22-B110A and Vibration ASTM D4169-09
- Compliance
 - PCI-SIG®, CE, FCC, CB, cURus (UL), ICES, VCCI, RCM, KCC
 - EMC testing for all major regions worldwide
 - Compliant with all applicable safety standards
 - Environmental, RoHS and REACH
 - Ethical, no Conflict Minerals

NAPATECH RECONFIGURABLE COMPUTING

NAPATECH.COM

Disclaimer: This document is intended for informational purposes only. Any information herein is believed to be reliable. However, Napatech assumes no responsibility for the accuracy of the information. Napatech reserves the right to change the document and the products described without notice. Napatech and the authors disclaim any and all liabilities. Napatech is a trademark used under license by Napatech A/S. All other logos, trademarks and service marks are the property of the respective third parties. Copyright © Napatech A/S 2022. All rights reserved.